

## Fork Gripper Fork F50<sup>©</sup>

### Technical description

Symmetrically opening robotic gripper suitable for manipulating and palletizing bags. It can be used in production lines which have certain specifications such as small size bags made of paper, plastic or fabric with weight between 20-50kg. The product is lifted from a roller conveyor via appropriate fork geometry design. The placement of the bag to the pallet is achieved by releasing the bag vertically achieving high speed in the palletizing procedure.

During the transportation, the bag is stabilized via vertical and side mechanical pads, in order to maintain the desirable shape and geometry, while at the same time achieving high speed of the procedure with safety.

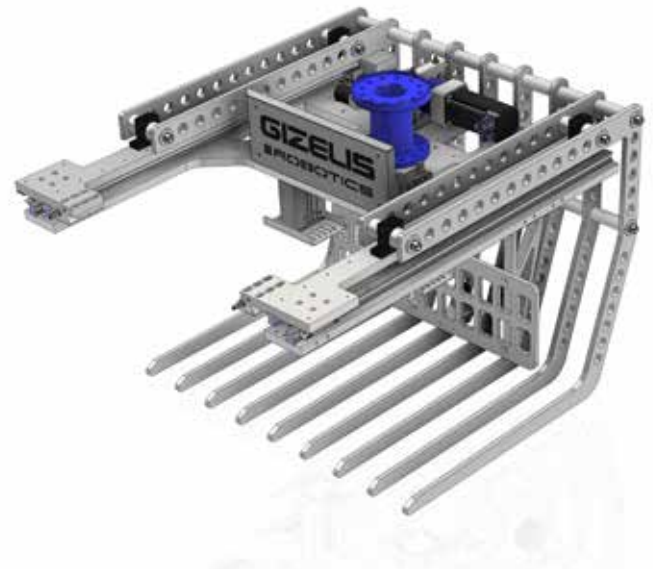

### Technical information

- ✓ Gripper dimensions (closed) 620 x 630 x 500mm
- ✓ Gripper dimensions (open) 950 x 630 x 500mm
- ✓ Weight 42kgr
- ✓ Space between center of claws 100mm
- ✓ Bag dimensions (max) 800 x 500 x 250mm
- ✓ Capability to transfer bag weighting 20-50kg maximum

### Basic features

- ✓ Robotic **servo driven** bag gripper
- ✓ Sturdy anodized aluminum construction
- ✓ Pneumatic high-speed motion system
- ✓ Side mechanical pads with independent pneumatic motion control
- ✓ Vertical mechanical pad for extra stabilization
- ✓ Aluminum anodized claws for the bag handling

